

POWER INFORMATION

Input Voltage: 100-240 V AC
 Input Frequency: 50/60 Hz
 Amperage: 0.65-0.33 A
 Electric Consumption: 69.3 W
 Plug: Country-specific

FEATURES

Programmable Timer
 Audible Status Alarm
 Push Button Control
 Onboard Operation Log
 Runtime Clock Display
 UV Lamp Life Meter
 Lamp Replacement Indicator
 Removable Carrying Strap
 13 foot Power Cord
 Ceiling or Wall Mount Kit
 Space Saving Design

APPLICATIONS

Animal Odor Removal
 Flood Repair
 Food Storage
 Garbage/Rubbish Collection
 Hotel Rooms
 Mold Control
 Odor Abatement
 Refuse Processing
 Rental Property Maintenance
 Restrooms/Washrooms
 Smoke Removal
 Vehicle Restoration

WARRANTY

Warranty valid in United States and Canada.
 Contact factory for warranty in other countries.
 One year Parts and Labor on entire unit.

MPZ System

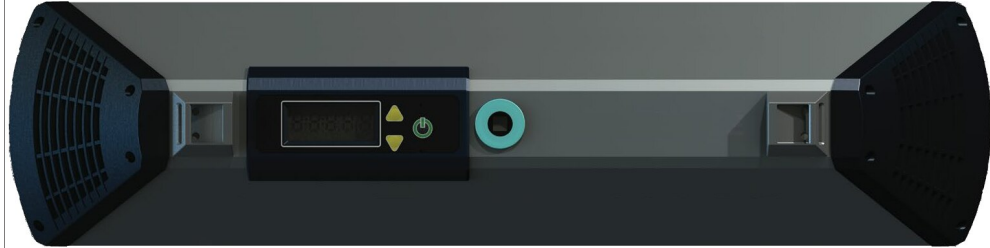

MPZ-II
Top View Shown



MPZ-II
Side View Shown



MPZ-II
End View Shown

- Eliminate odors, smoke, and chemicals
- Reduce bacteria, viruses, mold, and other micro-contaminants
- Industrial strength – a serious solution for serious problems
- Portable or fixed installations
- Programmable timer in 10 minute increments or continuous use
- Intended for use in unoccupied spaces
- Completely automated and chemical-free
- Maintenance free – requires simple annual UV Lamp replacement(s)

Product Certifications:



MPZ - I, II

Description: Commercial Air and Surface Purifier

Price per unit: £639 ex VAT

REORDER INFORMATION

Replacement UV Lamps

MPZ-I: 10-11100 (quantity 1)

MPZ-II: 10-11100 (quantity 2)

SPECIFICATIONS

Length: 21"

Width: 5.2"

Height: 4"

Weight: 6 lbs

Power Cord Length: 13'

CONTENTS

MPZ

UV Lamp(s) (pre-installed)

Owner's Manual and Installation Guide

Carrying Strap (optional)

Lock Key

Timer Reset Key

Wall Anchor (optional)

Mounting Screws (optional)

University College Dublin Study*

>99.99% reduction in bacteria



(a) prior to treatment

(b) after an 18 hour operation of MPZ-II

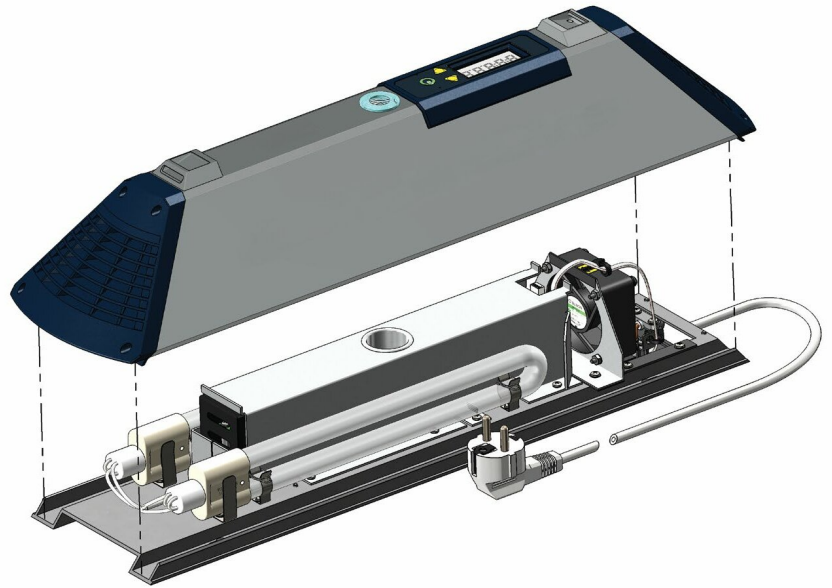
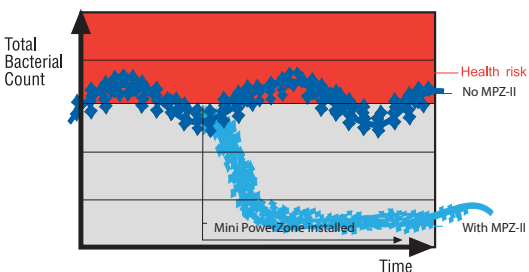

MPZ-II with cover removed Shown

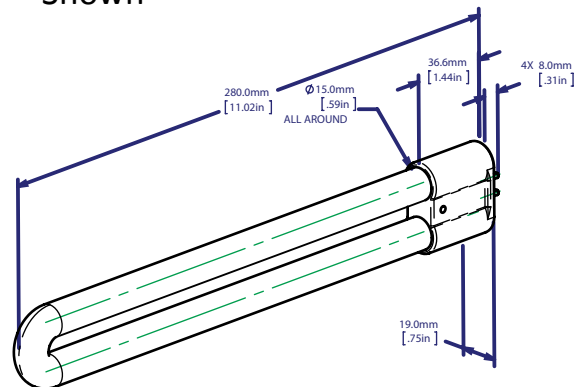

UV Lamp



MPZ-II with optional strap Shown



* Reference Number: V0273
School of Biomolecular and
Biomedical Science
University College Dublin
Belfast, Dublin 4, Ireland

Call or email us for bulk discounts!



INTELLIGENT FACILITY SOLUTIONS

Electric Works, 3 Concourse Way, Sheffield, S1 2BJ

United Kingdom: +44 (0) 114 354 0047

Eire: +353 190 36387

sales@ihdryers.co.uk

www.intelligenthanddryers.com