

# Intelligent

**The trusted independent experts for hand dryers  
and washrooms since 2012.**





for a greener tomorrow

# The Art of Hand Drying

A comparative study of the hygiene impact of using various hand drying methods, including high-speed air-curtain style hand dryers.



## Jidō Kansō [jee doh / kaan so]

1. Automatic hand dry movement - the art of drying your hands correctly using a jet towel hand dryer.

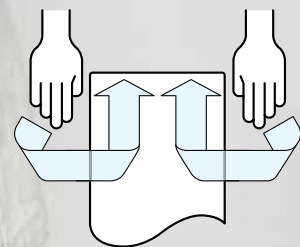

# Contents.

|  |                |
|--|----------------|
| <b>Introduction: The Art of Hand Drying</b>  | <b>4 - 6</b>   |
| <b>Chapter 1. What is the hygiene cost of drying our hands in the wrong way?</b>   | <b>7 - 8</b>   |
| We dry our hands in the wrong way. Overview of the impact (bacterial growth and spread)  |                |
| <b>Chapter 2. How should you dry your hands?</b>   | <b>9 - 12</b>  |
| Describe the Jidō Kansō movement.<br>How to prevent water and bacterial scattering   |                |
| <b>Chapter 3. What do Mitsubishi Electric Jet Towels offer?</b>  | <b>13 - 16</b> |
| Nozzles, antibacterial plastic, separate air intakes, drain tank, optional filters   |                |
| <b>Chapter 4. How important is the design to maintain the hygiene of the hand dryer?</b>   | <b>17</b>      |
| Safe alcohol cleaning, easy maintenance  |                |
| <b>Chapter 5. Compare the overall antibacterial performance</b>  | <b>18 - 20</b> |
| Illustrative examples of antibacterial performance in jet air dryer used properly (Jidō Kansō movement) and not (up-down movement) |                |
| <b>Certifications</b>  | <b>21</b>      |
| <b>Conclusion</b>  | <b>22</b>      |
| <b>References</b>  | <b>23</b>      |

## **Abstract.**

Clean hands are the most effective way to prevent infection spread. This doesn't include exclusively hand washing. Hand drying is a fundamental aspect of correct hand hygiene too, as it reduces the likelihood of microbial contamination and infection. However, this step is often overlooked and underestimated. This results in a public health hazard, which may have fatal consequences in environments with high hygiene requirements, such as hospitals.

Beside hand hygiene compliance, choosing the right hand drying method can additionally reduce the risk of cross-infections and provide additional benefits, e.g. energy saving and noise reduction. Main hand drying methods include towels, warm air dryers and the more recently developed air-curtain hand dryers.

This document contains an overview of why hand drying is important and the added value in terms of antibacterial performance of high-speed air-curtain hand dryers, in particular Mitsubishi Electric Jet Towel, compared to traditional hand drying methods.

## Introduction: The Art of Hand Drying

Hands are one of the main vehicles for transferring microbes between surfaces. Therefore, hand hygiene is the most important measure to prevent bacterial and viral infections. In addition to hand washing, drying of hands is an essential component of effective hygiene procedures. This action significantly decreases the likelihood of acquiring and transferring microbes.



### A dry environment

Although there is minimal to no difference between the number of bacteria on washed hands before and after effective drying, this additional step creates a dry environment that is hostile to microorganisms, as they thrive in wet conditions. Therefore, by drying hands correctly cross-contamination is reduced to a minimum. Re-use of fabric towels by many people can of course re-introduce a host of issues and should be avoided in any public or commercial convenience.

### HAIs

It has been estimated that, on any given day, one in 25 hospital patients are affected by healthcare-associated infections (HAI)<sup>1</sup>. These are a major cause of morbidity and mortality. In 40% of the cases, HAIs are caused by cross-infection<sup>2</sup>, which often occurs via the hands, e.g. from contact with healthcare workers or other patients.



The total bacterial counts on the hands of healthcare workers range from 39,000 to 4.6 million per  $\text{cm}^2$ <sup>3</sup>. Therefore, it comes as no surprise that the leading cause of infections originating in hospitals and spread of resistant bacteria is mostly attributed to healthcare workers' failure to perform appropriate hand hygiene and to transmission of microorganisms from contaminated hands of colonized patients.

These facts clearly show how hand hygiene practices are crucial in preventing HAI and cross-contamination. Furthermore, cleaning hands stops the development of antibiotic resistant bacteria and viruses.

### **Home and away**

Proper hand hygiene isn't only essential in healthcare settings, its potential to reduce the global burden of infectious disease has long been recognised. For example, cross-contamination at home and in food service establishments contributes to foodborne illness. Therefore, it is important to maintain correct hand hygiene practices, independently of the specific environment.

### **Reducing translocation**

Although most hand hygiene practices focus on hand washing, hand drying plays a fundamental role in controlling the spread of infectious diseases. By washing and drying hands, the number of microorganisms on the skin decreases hundredfold. In addition, hand drying heavily reduces the number of bacteria that can be subsequently translocated to skin, food or other goods. Studies have shown that a hand drying protocol can achieve a 94-99.8% reduction in bacterial translocation<sup>4</sup>.

### **Methods**

A number of methods to effectively dry freshly washed hands have been developed. These include cloth or paper towels, (warm) air dryers and air-curtain hand dryers. Each system has different hygienic features, strengths and weaknesses. Therefore, it is crucial to choose the method most suited and efficient for the facilities where it is located.

**Comparing Mitsubishi Electric Jet Towel air-curtain hand dryers with other methods**

This report looks at two Mitsubishi Electric Jet Towel air-curtain hand dryers: Slim and Smart.

It looks at their properties, how the high-speed hand drying method should be used and its potential to ensure a hygienic hand drying process, even in the most challenging environments.

In addition, it compares the antibacterial performance of Mitsubishi Electric Jet Towel Slim and Smart with other air-curtain hand dryers and hand drying methods.



# Chapter 1 - What is the hygiene cost of drying our hands in the wrong way?

Despite the importance of hand drying for infection control, hand hygiene protocols rarely specify how to properly dry hands. For example, even the European Standard for hygienic hand wash CEN – EN 1499:2013, technique widely used in laboratory and field studies, does not incorporate a hand drying step. Hence mistakes in hand drying practices are often performed.

## Completing the drying process

The most common error is to avoid fully drying wet hands. In fact, less than half the population dry their hands after washing<sup>5</sup>. Even when performed, the action is often carried out ineffectively, i.e. hands remain damp, or drying devices are not used properly, causing water droplets and bacteria to be spread in the washroom. As microbes may not be fully removed and cross-contamination is not averted, this inattention can heavily impact public health.

Moreover, skin excoriation can result from improperly dried, damp hands. This condition can subsequently increase the number of bacteria on the skin, eventually boosting the likelihood of infections on the damp hands themselves and of microbe transmission to other surfaces.

## Key factors in hand drying hygiene

Satisfactory antiseptic properties can be achieved with any drying methods, as long as the hands are fully dried, and the drying media is refreshed for each dry. However, different hand drying methods can greatly vary in their hygiene performance. A given hand drying method may excel in certain hygienic aspects but fail to address others. Therefore, it is important to identify the key factors in hand drying hygiene and to what extent each hand drying method fulfils - or not - these parameters.

**The hygiene performance of hand drying systems can be measured by assessing three parameters:**

- 1. Drying efficiency**
- 2. Bacterial removal from hands**
- 3. Bacterial transfer to objects**

Ideally, hand drying methods should excel in all three categories, namely they should dry the hands quickly and eliminate any remaining bacteria on the skin without spreading the microorganisms into the surroundings. A complete hygiene performance is however unreachable, therefore it's necessary to select the most effective method.



### Practical considerations at the point of delivery

In addition, the selected drying method should improve people's adherence to correct hand hygiene practices, minimizing the likelihood of improper drying of hands. For example, if using electric dryers is too time consuming, people may stop drying their hands before they are dry. Otherwise, people may fully skip drying their hands if the cloth towels appear damp, used, or dirty, or if the paper towels have not been replenished.

Based on these facts, selecting hand drying methods that are less hygienic or that do not encourage appropriate hand hygiene in the washroom can heavily decrease the final hygiene level obtained.

How should we dry our hands in order to avoid any health hazards, then?



## Chapter 2 - How should you dry your hands?

The main purpose of effective hand drying is drying hands without contaminating them further. Therefore, to maximise the effectiveness of the drying procedure, hands should not be left damp, and bacteria should neither be transferred by the hands nor scattered in the environment.

There are no best practice guidelines for hand drying with towels, whereas indications on how to use hand dryers are often conflicting: while some studies suggest rubbing hands to maximise bacterial removal, other suggests keeping them still.

In air-curtain hand dryers, hand drying guidelines provided by the manufacturer are available and it's important to follow them for a correct hand hygiene.

For Mitsubishi Electric Jet Towel high-speed air-curtain hand dryers, the right way to use the devices and properly dry hands is explained by the Jidō Kansō movement (see figure 1). This is a circular movement of the hands that maximises the hygiene performance of the hand drying practice.

When using Jet Towel Slim, Mitsubishi Electric 'hands-in' high-speed air-curtain hand dryer, the Jidō Kansō movement occurs vertically. It consists in inserting the hands from the sides of the drying area, instead of from the top. The hands should then be drawn up slowly through the air curtain generated. In this way, water on the hands is stripped off in a controlled manner. If the hands are not fully dried, the process should be repeated.

See Figure 1 and also the online guide at [www.gb.mitsubishielectric.com/jidokanso](http://www.gb.mitsubishielectric.com/jidokanso)

### Jidō Kansō [jee doh / kaan so]

#### Automatic hand dry movement

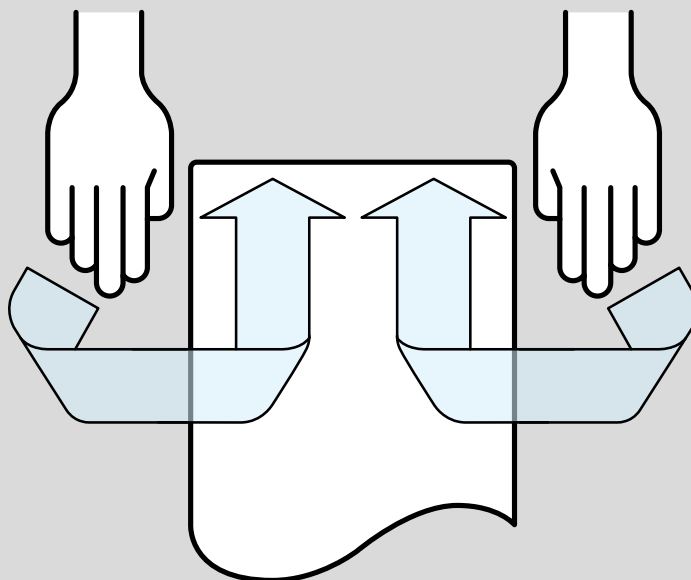

Figure 1

When the hands are dried according to the Jidō Kansō movement, droplets falling from the hands are not scattered out of the drying area. In this way, water and bacteria remain confined to the hand dryer and do not contribute to the creation of dirty or contaminated environments, either on the hands or in the washroom, and the risks of cross-contamination and bacterial growth are minimised.

#### How not to do it

Conversely, in other manufacturer's products, users are advised to insert hands from the top and repetitively move them up and down. In this way, the airflow pushes the water droplets up every time the hands are drawn down. Therefore, the airflow scatters water and microbes in the environment, and the drying process is less efficient, i.e. slower and less hygienic.



If hands are dried with a 'hands-under' Jet Towel Smart, the Jidō Kansō movement takes place horizontally. The hands draw circles under the air dryer. They should start externally, from the side of the device, and move towards the centre, where the airflow is. From there, they should move backwards towards the chest. The hands should be turned over for the second pass when using open type dryers. If the hands are not fully dried, the circular movement should be repeated.

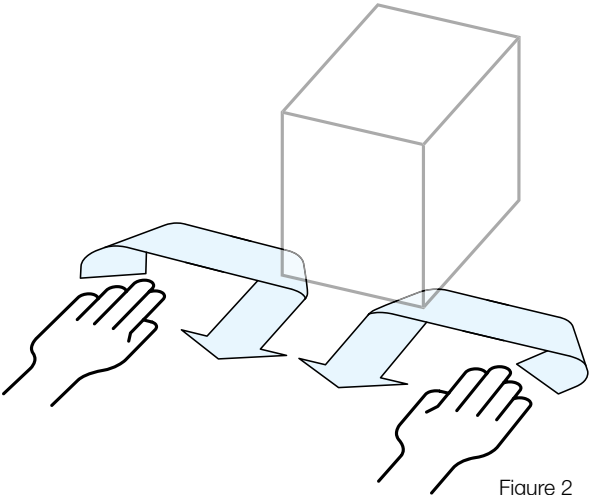

Figure 2



The Jidō Kansō movement - applied to either Jet Towel Slim or Smart - dries the hands faster. Different studies evidenced how people often spend well below 20 seconds to dry their hands. Mitsubishi Electric Jet Towel's ability to dry hands in 9 seconds ensures that, even after a short drying time, bacteria are removed, and hands aren't still damp, i.e. favourable environments for microbe proliferation are not created and bacteria are not easily translocated.

Similarly to the previous case, this movement minimises water and bacterial scattering in the surroundings and reduces water being blown back on to the user.

Furthermore, a quick method for hand drying may result in an improvement in hand hygiene compliance, which can further increase bacteria removal and decrease bacterial transfer in comparison to incomplete drying of hands.

The specific Jidō Kansō movement was conceived in accordance with the design of the drying devices, so that they could fit together and boost the level of hygiene obtained. The following section will examine the hygienic features of Mitsubishi Electric Jet Towel air-curtain hand dryers.

## Chapter 3 - What do Mitsubishi Electric Jet Towels offer?

Mitsubishi Electric developed the first high-speed air-curtain hand dryer in Japan in 1993. Already back then, it represented a revolutionary way to dry hands. Here is an overview of Jet Towel Slim and Smart main features.

### Slim

Mitsubishi Electric Jet Towel hand dryers are equipped with sensors that start or stop the airflow automatically as the hands are fully inserted in the drying area or removed. More precisely, a bottom sensor turns on the air stream when the hands are fully inserted, and the upper sensors stop air flow once hands have left the dryer. In this way, the risk of scattering airborne particles in the washroom is reduced even further. Moreover, it helps eliminate the need to touch surfaces, which is a potential source of cross-contamination.

As awkward bending or reaching may discourage proper drying wet hands, Mitsubishi Electric took into consideration the different heights of its users when designing the sensors in its air-curtain hand dryers. Children can use Jet Towel Slim as easily as adults, thanks to two specially placed sensors in the hand drying area.



The drying process of high-speed air-curtain hand dryers is extremely fast and efficient as it does not rely on evaporation. In this way, the airflow doesn't need to be heated and the hands don't need to be rubbed. Drying time using an unheated version of the product is around 11 seconds, the option exists for a heated air flow version which cuts the drying time to 9 seconds and gives added comfort in cold washrooms.

## Smart

Jet Towel Smart is a 'hands-under' high-speed air-curtain hand dryer and it was designed without a receptacle for water splashes. However, it was specifically engineered to keep the water splashes (and bacteria) confined to a small area, instead of letting them spread in the environment. To do that, the splashes are forced on to the wall, which can be easily cleaned. In addition, this design avoids the formation of water puddles on the ground.

Looking at airflow analysis and comparing an air-curtain high-speed hand dryer and a high-speed warm air hand dryer that produces a column of air, there are major differences. An air-curtain hand dryer effectively draws a thin line of air across the surface of the hand and pushes the water off in front of it. Then, as in the Mitsubishi Electric Smart unit, the flow is directed towards the back wall.

Dryers that use a column of high-speed warm air work by blowing the water off the hands in a downward stream of air that travels a lot further and with a higher volume of air, pushing further into the room and carrying the moisture from the hands with it.

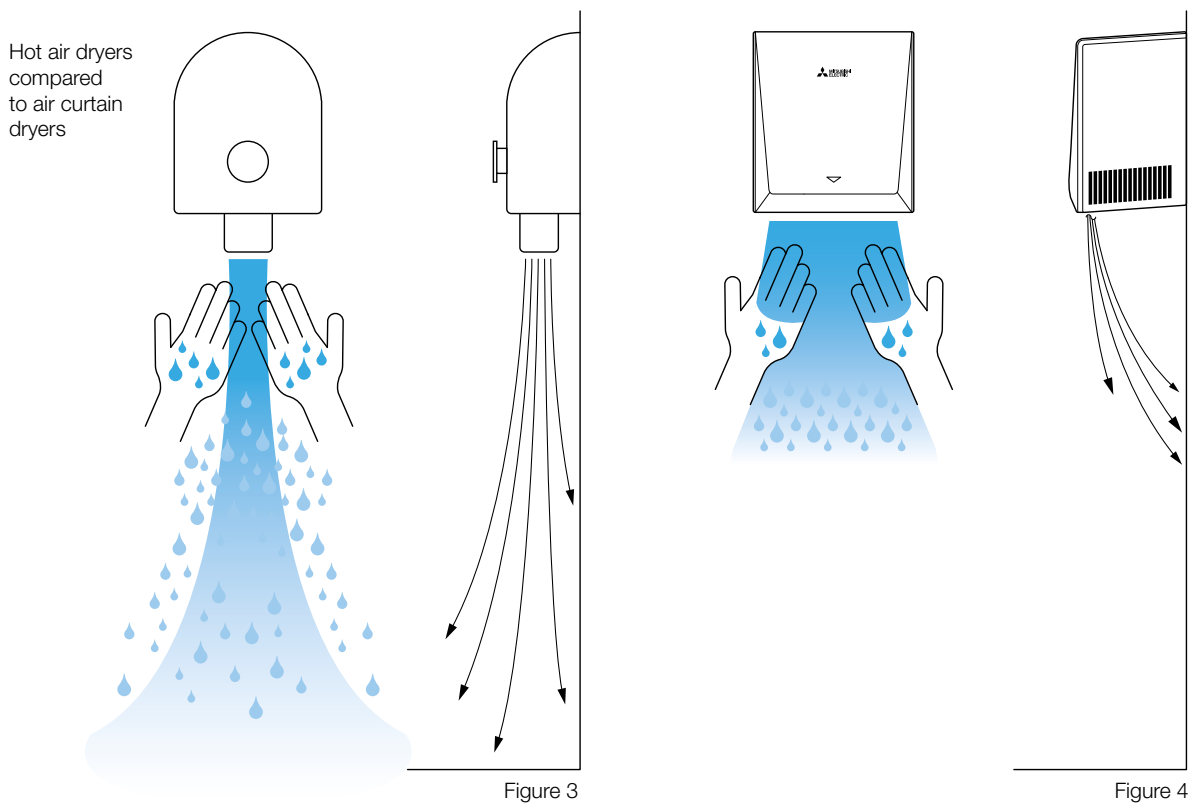

**Alternatively, Jet Towel Slim is a 'hands in' high-speed hand dryer equipped with an apparatus to collect the water droplets falling from wet hands and subsequently disposed of them. In practice, the excess water is channelled via a hose-less lateral duct and collected in an easily-removable drain tank.**

See Page 17 for a diagram

## Slim and Smart

Mitsubishi Electric also equipped its Jet Towel Slim and Smart with air filters. These are located under the drain tank in Jet Towel Slim or right up against the side of the intake grill in Jet Towel Smart. Although some high-speed hand dryers have HEPA filters to purify the blown air, Mitsubishi Electric found that these filters clog rapidly. This negatively affects the efficiency of the hand dryer by drastically reducing the airflow while the hygiene effectiveness of the filters diminishes over time. In addition, HEPA filters cause large loads on the motor, increase noise and power consumption, are expensive and are difficult to replace, and do not show any antibacterial performance.

Therefore, Mitsubishi Electric designed its high-quality Clean Filters differently. These are cheaper, do not contribute to noise generation, and do not affect motor performance. In addition, Jet Towel filters remove dust and bacteria with particle size above 1 micron and subsequently sterilise them, thanks to the embedded silver ions, which provide antibacterial properties.

The metal ions kill bacteria by penetrating their cell walls and impairing normal cell functions, e.g. interfering with cell homeostatic processes, having disruptive effects on mitochondria, proteins and DNA. If required, Jet Towel Slim can be equipped with high-grade filters, with smaller pore size, to remove smaller particles.

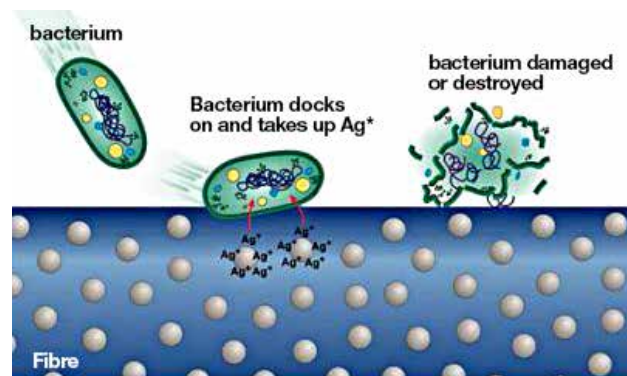

Figure 5

## Comparative proof of Antibacterial effect

Following 24-hour culturing using a film contact method in Mitsubishi Electric laboratories



**Bacteria accumulation**



**Without antibacterial treatment**



**With antibacterial treatment**

Silver ions attached to the cell walls of general cellular bacteria, curbing protein synthesis and reaction to control bacterial growth and reproduction.

Figure 6



## Antibacterial Surfaces

To provide further antimicrobial protection, all the main surfaces of Jet Towel Slim and Smart are made of antibacterial plastic, where silver or zinc ions are embedded in the material surface. While antibacterial coatings tend to wash out as they are constantly exposed to water cleaning. Therefore, antibacterial protection throughout Jet Towel Slim plastic is maintained even after aging with light and cleaning, ensuring continuous and prolonged protection.

To reduce dirt build-up, Mitsubishi Electric reduced the number of joints in the main drying area down to one. This allows operatives to easily clean the device to a high standard.

Finally, the air intakes are designed to reduce contamination from water and bacteria. These are separate from the water tank in Jet Towel Slim, in order to reduce the risk of water (and bacteria) intake in the airflow. In Jet Towel Smart, the air intakes are located on the side of the device, rather than on the bottom in order to prevent recirculation of water from wet hands. Thanks to these expedients, the air blown on to the hands is more hygienic.



Despite the advanced antibacterial and hygienic properties of Mitsubishi Electric Jet Towel hand dryers, it is important maintenance and cleaning are carried out regularly to secure the hand drying process remains hygienic.

## Chapter 4. How important is the design to maintain the hygiene of the hand dryer?

The maintenance of a clean environment around hand dryers is essential for maintaining a non-hazardous washroom environment. The area should be easily accessible in order to avoid grime build-up (bacterial removal from any surface) and bacterial translocation.

Mitsubishi Electric Jet Towel hand dryers are designed to be easy to clean and meet high hygiene standards required by specific facilities, such as hospitals. The measures adopted by Mitsubishi Electric include:

- The surfaces of the high-speed hand dryers can be safely cleaned with alcohol-based cleansers, which are the most common disinfectants used to sanitise surfaces. As most sanitisers contain 75% ethanol, Mitsubishi Electric made sure its plastic could sustain up to 83% ethanol content.
- In Jet Towel Slim, the main drying area is easily accessible for cleaning.
- The side panel covering the drain port leading to the collection tank can be removed easily to allow the channel to be cleaned easily.
- The drain tank present in Jet Towel Slim can be easily removed to empty it from the water collected during use and to clean the surfaces.
- The air filters can be easily cleaned, washed or replaced.
- To avoid water accumulation, either in the hand dryer or in the washroom, Mitsubishi Electric equipped Jet Towel Slim with a removable water tank to dispose of collected water and Jet Towel Smart was designed to minimise water drops falling onto the ground.

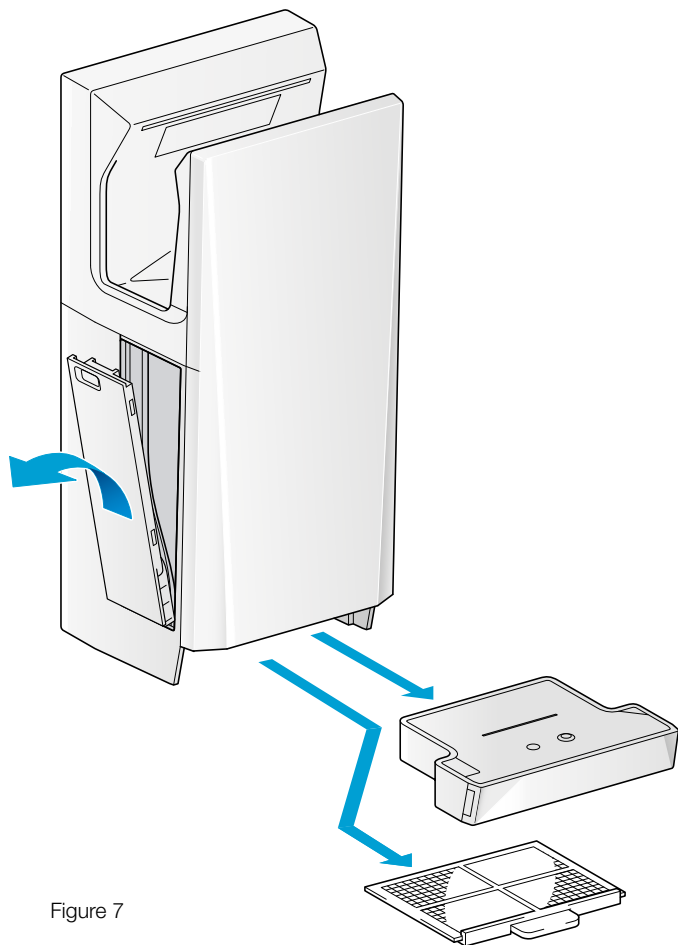

Figure 7

## Chapter 5 - Compare the overall antibacterial performance

Mitsubishi Electric Jet Towel high-speed hand dryers are designed to provide a complete and safe hand drying system, when used properly. However, improper use may greatly affect the hygienic features. If hands are not dried according to the Jidō Kansō movement, the drying efficiency, bacterial removal and translocation features of Mitsubishi Electric Jet Towel hand dryers can be affected. Therefore, it is important to apply the Jidō Kansō movement when drying wet hands.

Here is a comparison of the antibacterial performance of Mitsubishi Electric Jet Towels with other hand drying methods, in particular warm air hand dryers.

Results on hygiene performance of warm air hand dryers and Mitsubishi Electric Jet Towel

|                               | <b>Paper towels</b>                               | <b>Warm air hand dryers</b>                | <b>Mitsubishi Electric Jet Towel high-speed air-curtain hand dryers</b> |
|-------------------------------|---|--|---|
| <b>Bacterial removal</b>      | 150% increase in CFU                              | 150% increase in CFU                       | 0% increase in CFU  |
| <b>Bacterial transfer</b>     | Up to 47 CFU scattered / drying cycle             | Up to 47 CFU scattered / drying cycle      | 0 CFU scattered / drying cycle  |
| <b>Drying efficiency</b>      | 30-40 s   | 30-40 s                                    | 9-11 s  |
| <b>Impact on human health</b> | Nearly 12 units of disability adjusted life years | 13 units of disability adjusted life years | <4 units of disability adjusted life years                              |

Figure 8

## Bacterial removal

Different studies assessed the number of bacteria recovered from hands after drying with different procedures. To do this, volunteers were asked to press their fingertips into bacterial growth media before using the washroom, then wash and dry hands using different hand drying methods. Subsequently, their fingertips were sampled again. The results show that paper towels and high-speed air-curtain hand dryers performed considerably better (less residual bacteria) than warm air dryers<sup>6</sup>, however the standard deviation of paper towels was greater than for high-speed air-curtain hand dryers, meaning that bacterial removal can greatly differ every time hands are dried.

Another study found that the number of bacteria were between 10 and 5000 bacterial colony forming units (CFU) per hand with a Mitsubishi Electric Jet Towel Slim high-speed air-curtain hand dryer. These values were comparable with the number of bacteria on freshly washed hands (approx. 13-5000 CFU/hand). Therefore, drying hands with Mitsubishi Electric Jet Towel is hygienic and it neither increases the number of bacteria on hands, neither contribute to bacterial transfer.

## Bacterial transfer

Although hands may be water- or bacteria-free, there may be a sensible release of particles in the surroundings. Studies found that water droplets can be scattered up to 2.44 m away from the drying device, being it a paper towel or a hand dryer<sup>7</sup>.

Similarly to water, microbes (bacteria, fungi or viruses) can be found up to 3 m away from the drying source, studies found. When the main drying area of a Mitsubishi Electric Jet Towel hand dryer is covered with bacteria, these are not scattered out of the hand dryer even after 30 minutes of continuous operation. Therefore, Mitsubishi Electric Jet Towel hand dryers do not cause bacterial transfer when in use.

In addition, the number of airborne bacteria near Mitsubishi Electric Jet Towel Slim (10-25 cm distant) and in the room air (up to 1.5 m away from it) was measured between 20/100L and 42/100L, level comparable to the average airborne bacteria count in washrooms ( $69.1 \pm 30.7/100L$ )<sup>8</sup> and offices ( $52.6 \pm 41.5/100L$ )<sup>8</sup>. This further supports the fact that the Mitsubishi Electric Jet Towel doesn't cause visible bacterial transfer. For comparison, warm air hand dryers scatter up to 47 CFU at every drying cycle<sup>9</sup>.

While these measures cannot be easily applied to paper towels to measure bacterial transfer, a study found that an average of 2.627 log CFU/25cm<sup>2</sup> can be found in the vicinity of bins for paper towels<sup>7</sup>.

## Drying efficiency

Drying efficiency is also streamlined in high-speed air-curtain hand dryers, in particular for Mitsubishi Electric Jet Towels. While warm air dryers require 30-40 s to completely dry wet hands, paper towels and high-speed hand dryers perform the same task faster. To achieve a minimum of 90% dryness of the hands, paper towels require 10-11 seconds<sup>10</sup>. Mitsubishi Electric Jet Towel Slim and Smart high-speed air-curtain hand dryers go a step further and effectively dry the hands in 9 seconds for the heated versions and 11 seconds for the unheated models.

### **Impact on human health**

A life cycle impact assessment showed that the impact of high-speed hand dryers on human health during use is considerably lower than those of other drying systems. More precisely, paper towels and warm air dryers can affect human health approximately 3 and 3.5 times more than high-speed air-curtain dryers respectively<sup>11</sup>.

The high-speed air-curtain hand dryers used in the life cycle impact assessment have a lifetime usage of 350,000 pairs of hands dried over the 5-year product life span. The average product lives of Mitsubishi Electric Jet Towels are nearly 3 times higher, with lifetime usages of 1,022,000 (they last for over 400 uses every day for 7 years). Therefore, their impact on environmental sustainability and therefore directly on human health is likely to be even lower.

## Certifications

Mitsubishi Electric Jet Towel high-speed air-curtain hand dryers have been accredited with NSF/ANSI 169 certification by NSF International (NSF) and the American National Standards Institute (ANSI) in recognition of their hygienic operation.

In addition, Mitsubishi Electric Jet Towel Slim and Smart adhere to the JIS B 9908 guidelines provided by the Japanese Standards Association (JSA) for air filters. This standard is equivalent to CEN - EN ISO 15957:2015.

These certifications provide further evidence on the suitability of Mitsubishi Electric Jet Towels in installations where bacterial transfer and microbial management are key concerns.

### Certified by NSF International

NSF International, an independent third-party public safety health and standards organization, has certified Jet Towels to be compliant to its rigorous requirements (NSF/ANSI 169).



## Conclusions

Hand hygiene is fundamental in both healthcare and community settings, as it can prevent diseases and infections, as well as reduce cross-contamination. Hand drying is an essential step in hand hygiene practices. It has been demonstrated that damp hands are more likely to acquire microorganisms or to transfer them.

Although all drying methods are effective, the choice of the drying method can influence the hygiene level achieved, for that concerns drying efficiency, bacterial removal, bacterial transfer, as well as promotion of hand hygiene compliance. Further, some other hand drying systems may pose health risks to humans that should be examined.

This paper shows that Mitsubishi Electric Jet Towel high-speed air-curtain hand dryers ensure the highest hygiene standards are met. Both Jet Towel Slim and Smart hand dryers outperform other drying methods in terms of drying efficiency, bacterial removal and bacterial transfer.

Thanks to the Jet Towel design and the Jidō Kansō movement, the innovative drying procedure created by Mitsubishi Electric, the high-speed air-curtain hand dryers excel in all three fields of hand hygiene, and they also maximise hand hygiene compliance among users. Therefore, they are suitable for both community and healthcare settings, which demand strict hygienic practices.

In addition, high-speed air-curtain hand dryers are also associated with lower impacts on human health, like promoting environmental sustainability. By ensuring minimal health hazards, exposures and risks, Mitsubishi Electric Jet Towel provide the safest way of hand drying.

# References

1. Centers for Disease Control and Prevention, 2015. Healthcare-associated infections (HAI) progress report. Last updated March, 3.
2. Weinstein, R.A., 1991. Epidemiology and control of nosocomial infections in adult intensive care units. *The American Journal of Medicine*, 91(3), pp.S179-S184.
3. WHO Guidelines on Hand Hygiene in Health Care: First Global Patient Safety Challenge Clean Care Is Safer Care. Geneva: World Health Organization; 2009. 5, Normal bacterial flora on hands. Available at: <https://www.ncbi.nlm.nih.gov/books/NBK144001/>
4. Patrick, D.R., Findon, G. and Miller, T.E., 1997. Residual moisture determines the level of touch-contact-associated bacterial transfer following hand washing. *Epidemiology & Infection*, 119(3), pp.319-325.
5. Malinowska-Borowska, J., Wolny, M. and Krause, M., 2015. Hand washing practices of the residents of Silesia (Poland) based on observations in public toilets. *Journal of Water Sanitation and Hygiene for Development*, 5(1), pp.107-114.
6. Snelling, A.M., Saville, T., Stevens, D. and Beggs, C.B., 2011. Comparative evaluation of the hygienic efficacy of an ultra-rapid hand dryer vs conventional warm air hand dryers. *Journal of Applied Microbiology*, 110(1), pp.19-26.
7. Margas, E., Maguire, E., Berland, C.R., Welander, F. and Holah, J.T., 2013. Assessment of the environmental microbiological cross contamination following hand drying with paper hand towels or an air blade dryer. *Journal of Applied Microbiology*, 115(2), pp.572-582.
8. Chan, W.Y., Mui, K.W. and Wong, L.T., 2009. Airborne bacteria assessment in an office washroom. Proceedings of 2009 conference on Green Building Towards Eco-City, 11-14 October, Taipei, Taiwan, Paper E01, 1-9. Available at: [http://www.irbnet.de/daten/iconda/CIB\\_DC25527.pdf](http://www.irbnet.de/daten/iconda/CIB_DC25527.pdf)
9. Dawson, P., Northcutt, J., Parisi, M., and Han, I. 2016. Bioaerosol formation and bacterial transfer from commercial automatic hand dryers. *Journal of Food: Microbiology, Safety & Hygiene*, 1(2), 108, 6 pp.
10. Redway, K., Fawdar, S. 2008. European Tissue Symposium: A comparative study of three different hand drying methods: paper towel, warm air dryer, jet air dryer. Available at: <http://www.europeantissue.com/pdfs/090402-2008%20WUS%20Westminster%20University%20hygiene%20study,%20nov2008.pdf>.
11. Montalbo, T., Gregory, J. and Kirchain, R., 2011. Life cycle assessment of hand drying systems. Massachusetts Institute of Technology, 113.